

A0100DP

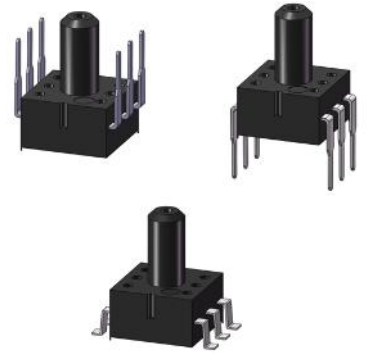

1. KEY FEATURES:

- Piezo-resistive silicon micro-machined sensor
- Gauge type pressure sensor
- I2C / SPI Interface
- Pressure range: 100KPa (5KPa/10KPa/20KPa/40KPa/100KPa/200KPa/300KPa/500KPa/1000KPa)
- Pressure Sensitivity: 0.027 Pa/LSB
- 24 Bit Σ - Δ ADC
- Temperature Compensation: $-40^{\circ}\text{C} \sim 85^{\circ}\text{C}$
- Operating voltage 3.0V
- Operating mode current: $\sim 0.6\text{mA}$ (typical)
- Sleep Mode current: 0.1 μA (typical)
- SOP6 or DIP6 package
- RoHS compliant and Halogen-free
- abs. accuracy around $\pm 0.5\%$ FS

2. PRODUCT INTRODUCTION:

A0100DP series product is the pressure sensor which measures gauge pressures. It consists of a silicon micro-machined sensing element chip and a signal conditioning ASIC. The ASIC is equipped with a 24-bit resolution Σ - Δ ADC and outputs a highly precise pressure value as a digital value.

A0100DP series products provides digital output interface. It can achieve ESD robustness, fast response time, high accuracy and linearity as well as long-term stability. All measurement data is fully calibrated and temperature compensated. In addition, it allows for easy system integration.

This series pressure sensor use SOP6 or DIP6 package which is suitable for lots application.

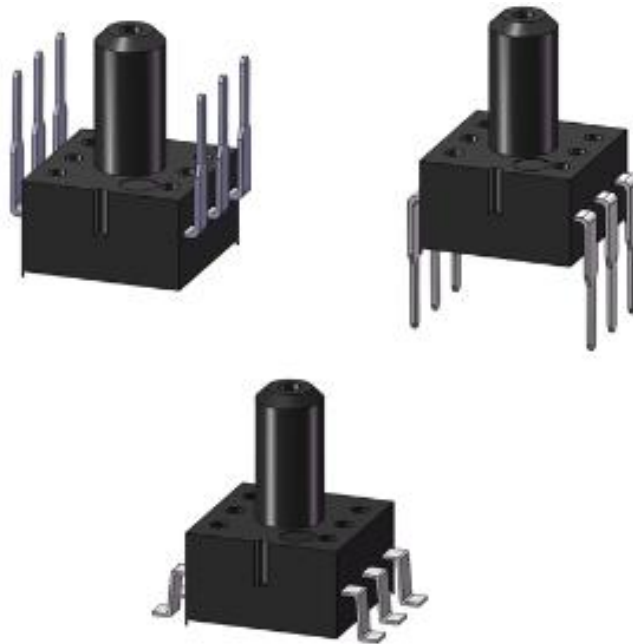

3. APPLICATION

- Automobile electronic
- Consumer electronics
- Household electronic
- Industrial monitor and control
- Medicine care

4. PERFORMANCE SPECIFICATIONS

Table 1 Specifications

Parameter	Condition	Min.	Typical	Max.	Unit	Remark
Supply Voltage		1.8	3	3.6	Vdc	
Supply Current			1		mAdc	
Pressure range	100 (5/10/20/40/100/200/300/500/1000)				kPa	
Sleep current	25°C	–	0.1	0.3	μA	
Relative accuracy	25°C~40°C	–	±0.03	–	hPa	
Absolute accuracy	-40°C~125°C	–	±4	–	hPa	
Linearity		--	0.2	0.5	%FS	
Resolution of output data in ultra high resolution mode	Pressure	–	0.05	–	Pa	
	Temperature	–	0.01	–	°C	
Absolute accuracy temperature	25°C	–	±0.5	–	°C	
	0°C~65°C	–	±1.0	–	°C	
TCR		1500	2000	2500	ppm/°C	
Stability		0.2			%FS/Y	
Hysteresis		--	0.05	0.1	%FS	
Overpressure		3X			--	
Operation temperature		-40	--	125	°C	
I2C Clock Frequency	3V	–	--	3.4	MHz	
SPI Clock Frequency	3V	–	1	20	MHz	

5. APPLICATION SCHEMATIC

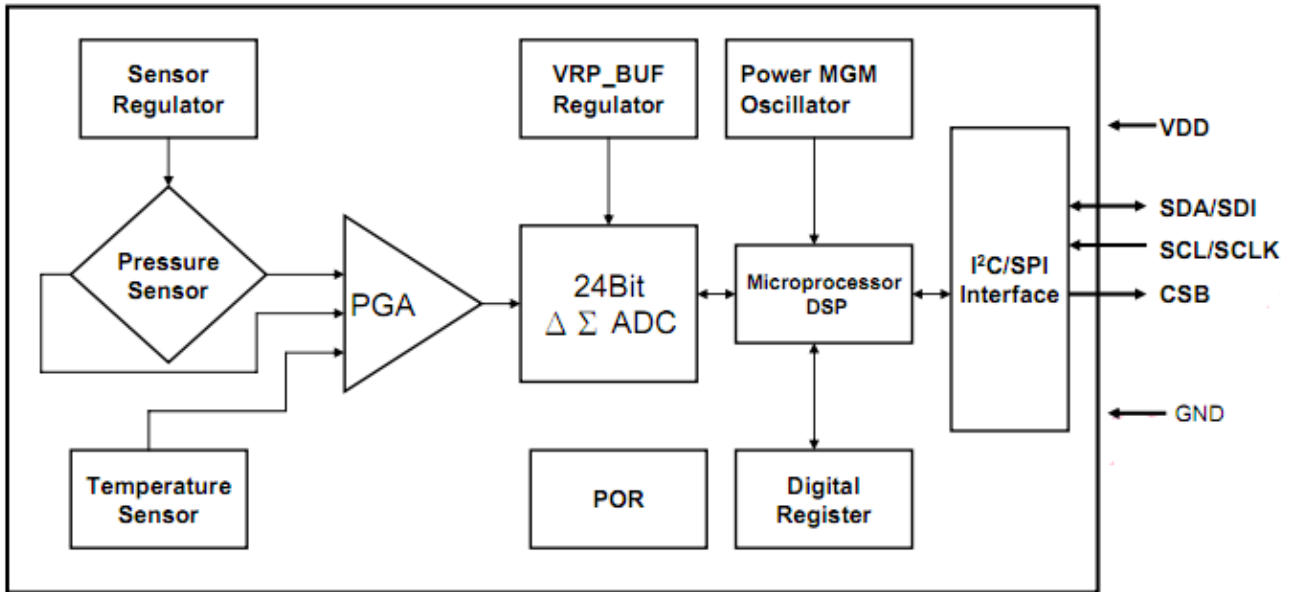

pressure sensor schematic

6. CONNECTIONS

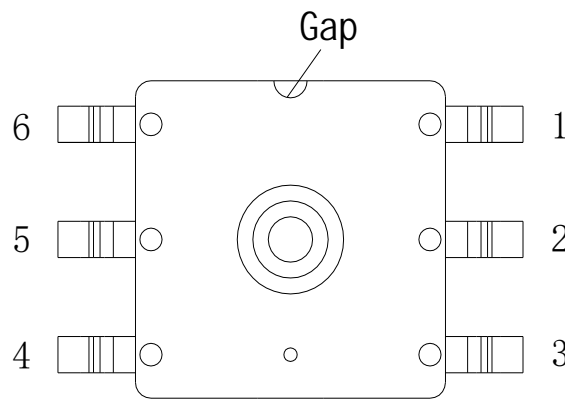

Top view

Table2 Definition

Pin number	Definition	Definition
1	GND	Connected to GND
2	SCL	Clock input for I2C/SPI
3	SDA	(1) Data in/out for I2C. (2) Data input for SPI.
4	CSB	Chip select
5	VDD	Positive supply voltage
6	NC	NC

Remark: the connections definition is same for SOP and DIP package product

7. CONNECTION DIAGRAM

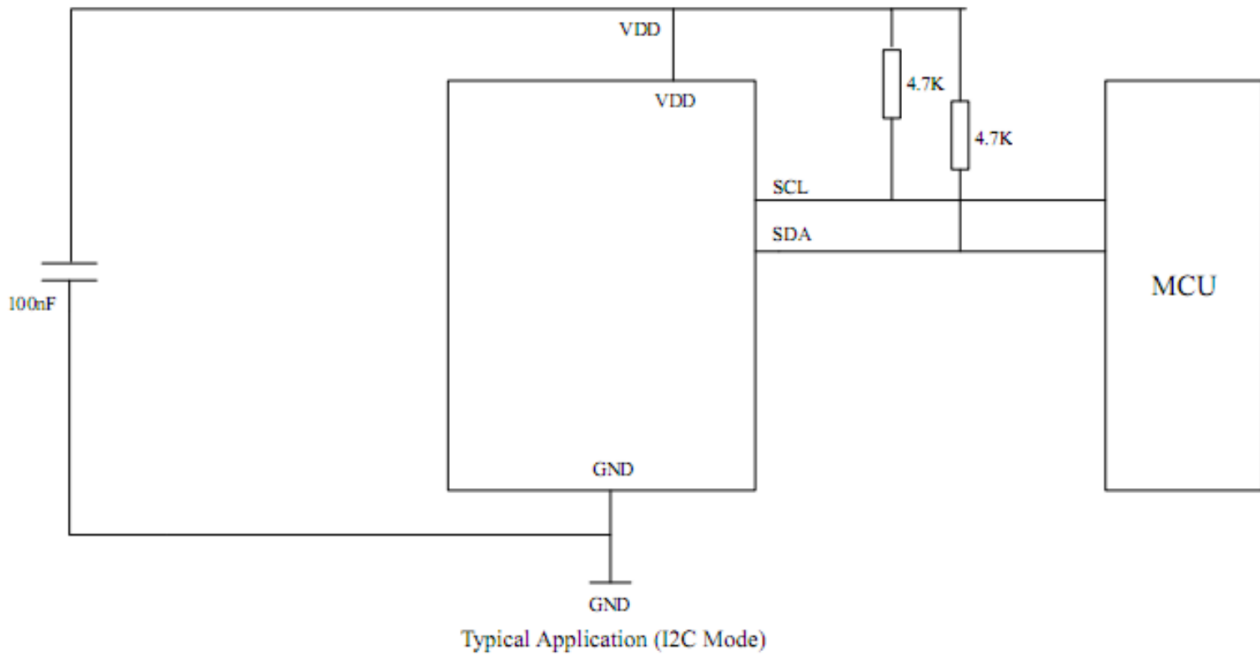

Notes:

- The recommended value for C1 is 100nF
- The value for the pull-up resistors R1, R2 should be based on the interface timing and the bus load; a normal value of R1 is 4.7kΩ, R2 is 4.7kΩ.

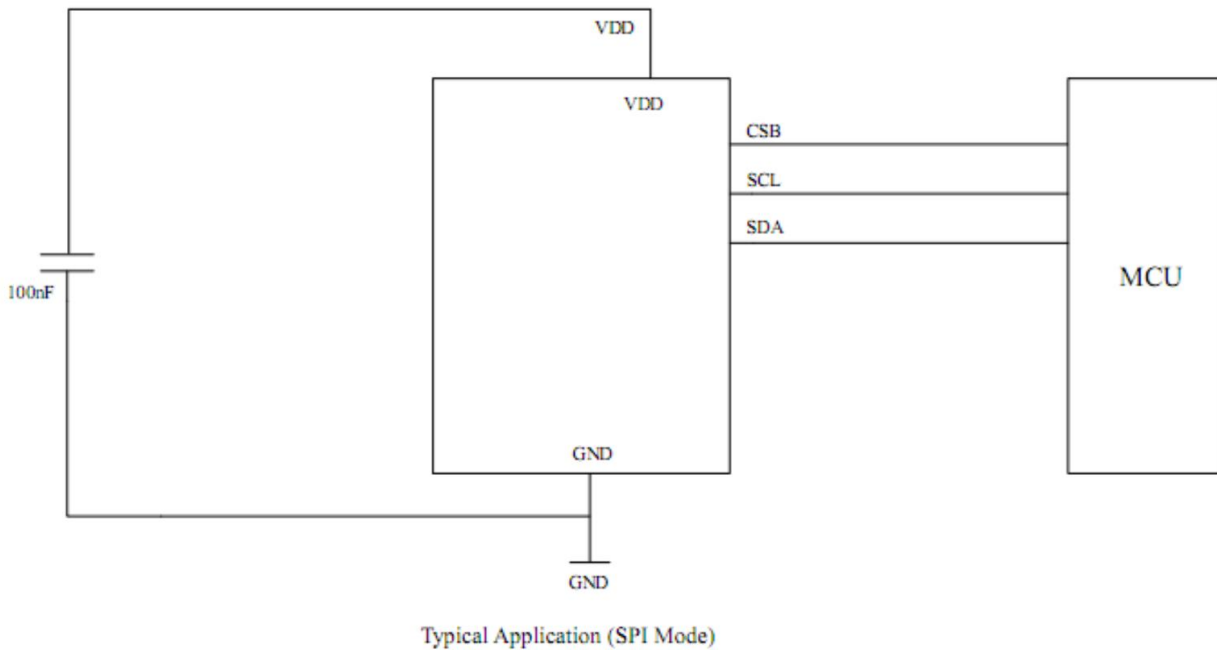

A0100DP Series

Low-Power, High-Resolution
Pressure Sensor

I2C INTERFACE

- IIC Device Address

	Device Address							IIC W/R
	Bit7	Bit6	Bit5	Bit4	Bit3	Bit2	Bit1	Bit0
Default	1	1	0	1	1	0	1	0/1

- IIC Protocol

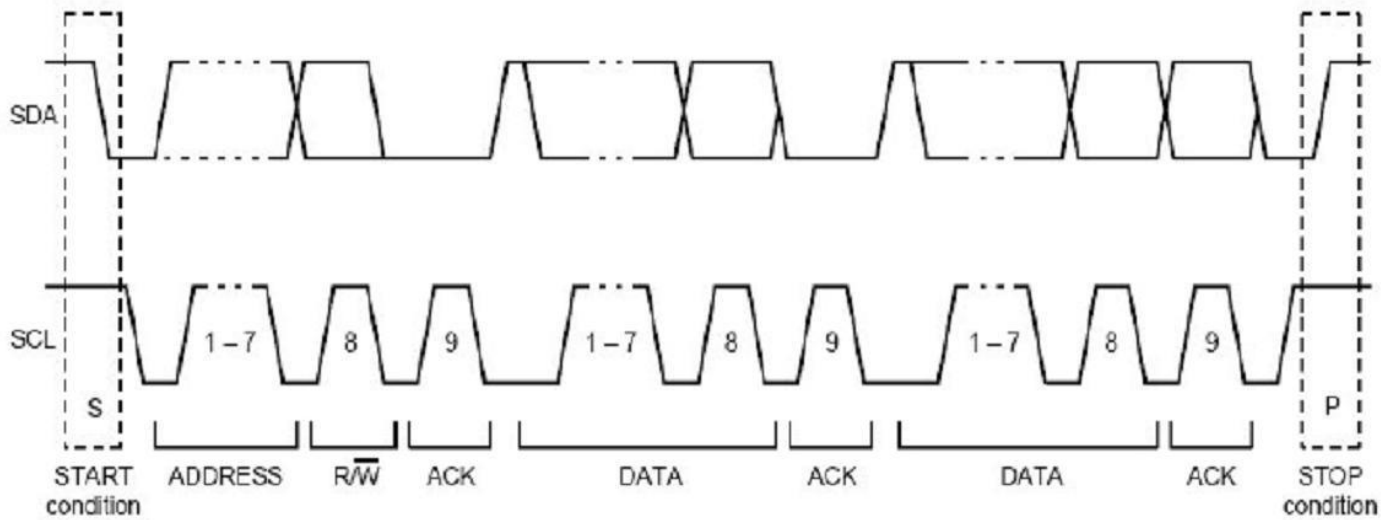

PRESSURE AND TEMPERATURE ORDER

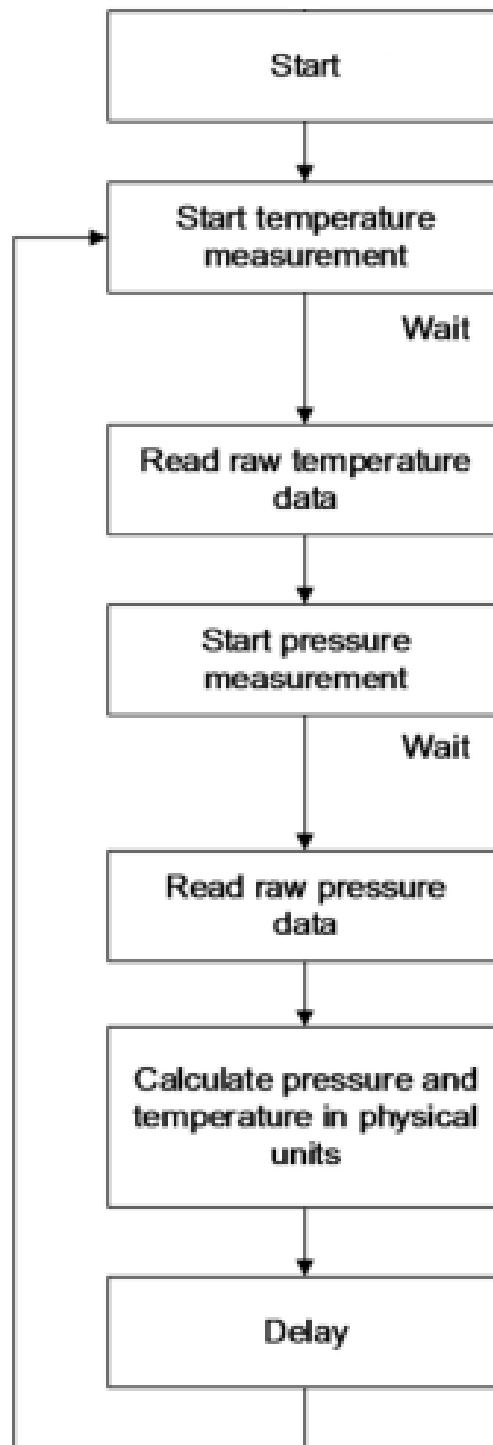

A0100DP Series

Low-Power, High-Resolution
Pressure Sensor

Start

T_{MIN} = -40°C T_{MAX} = 85°C T_{REF} = 25°C



Read digital pressure and temperature data

Reg	Description		R/W	Default
0x30	CMD	0x0A, perform one output 0x0B, Continuous output 0x1B, 62.5ms interval output 0x2B, 125ms interval output 0xFB, 1s interval output	W	0x00
0x06	PRESSURE_MSB	Press out<23:16>	R	0x00
0x07	PRESSURE_CSB	Press out<15:8>	R	0x00
0x08	PRESSURE_LSB	Press out<7:0>	R	0x00
0x09	TEMP_MSB	Temp out<15:8>	R	0x00
0x0A	TEMP_LSB	Temp out<7:0>	R	0x00
0x02	STATUS	After sending the CMD, poll the bit0 value of STATUS to judgment if the conversion is complete. Note that the data will be automatically cleared after it is read.	R	0x00

*Reg0x06-Reg0x08: 24 bits ADC output data with an LSB



Calculate

	Size [bit]	Zero Condition	Below Zero	Above Zero
PRESSURE	24	8388608	long ad = PRESSURE_MSB; ad << 8; ad = PRESSURE_CSB; ad << 8; ad = PRESSURE_LSB; float v = ad / 8388608;	long ad = PRESSURE_MSB; ad << 8; ad = PRESSURE_CSB; ad << 8; ad = PRESSURE_LSB; float v = (ad - 16777216) / 8388608;
TEMP	16	32768	long ad = TEMP_MSB; ad << 8; ad = PRESSURE_LSB; float v = ad / 256;	long ad = TEMP_MSB; ad << 8; ad = PRESSURE_LSB; float v = (ad - 65536) / 256;

* PRESSURE: It also needs to be converted according to the pressure range, Using the driver C code is strongly recommended. Please contact with AO for details.

A0100DP Series

Low-Power, High-Resolution
Pressure Sensor

● IIC timing diagram

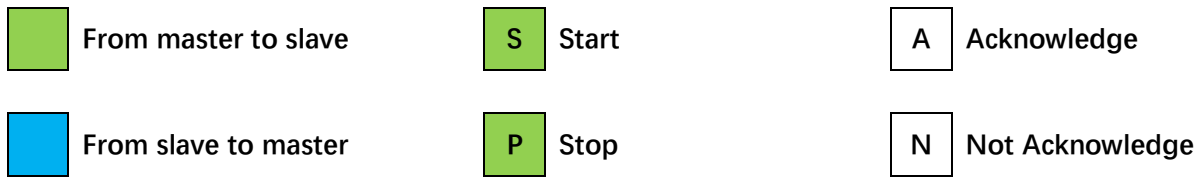

Write Data (IIC Write)

(a) conversion command

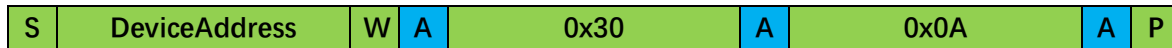

Read Data (IIC Read)

(a) After sending the temperature conversion command, read 16bit data from the output buffer

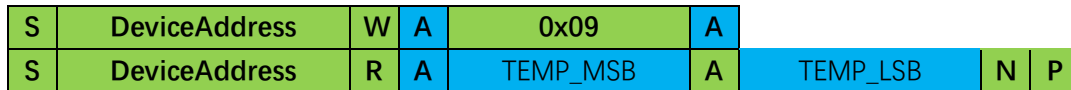

(b) After sending the pressure conversion command, read 24bit data from the output buffer

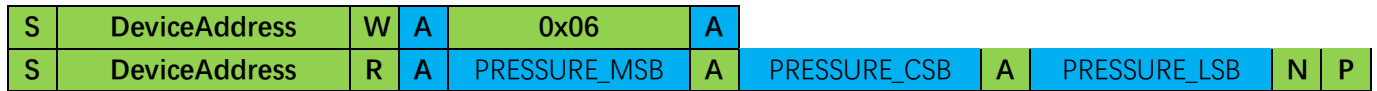

8. PRODUCT DIMENSIONS

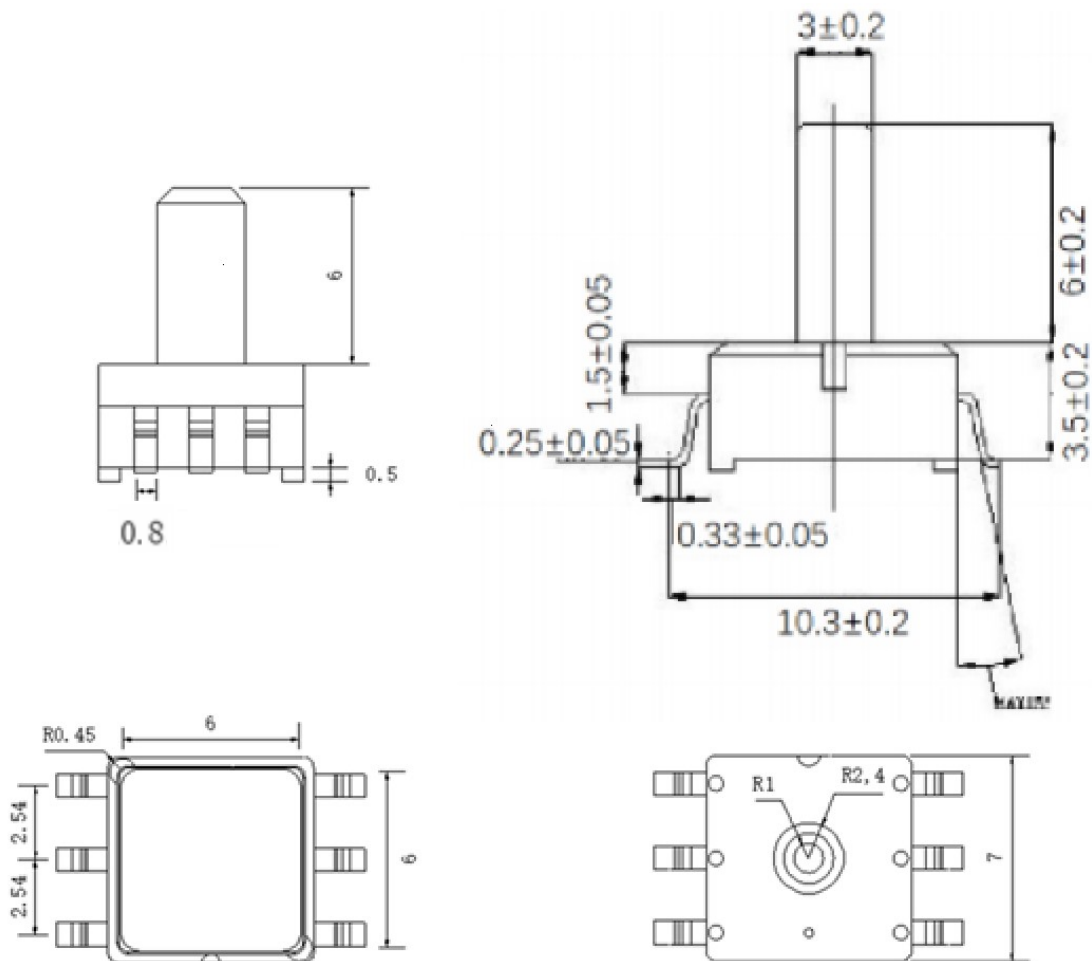
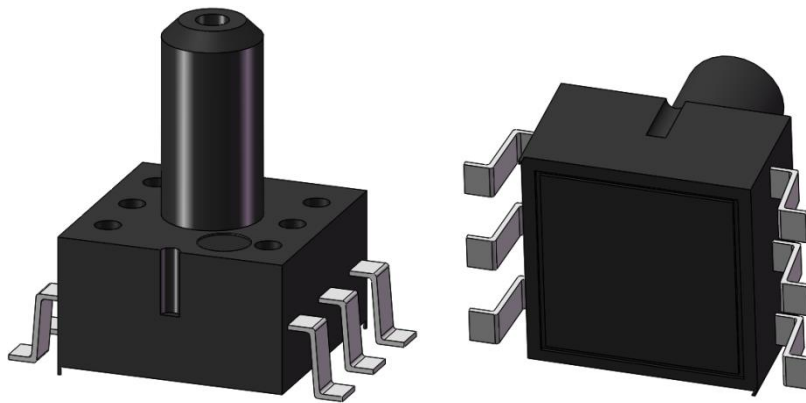

AO100DP SOP6 Top Tube TOL : ± 0.2mm

Digital Pressure Sensor

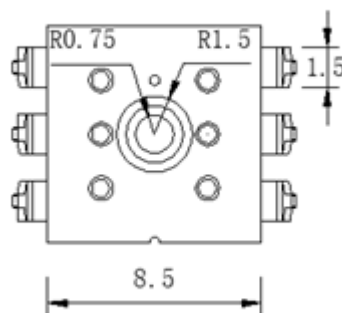
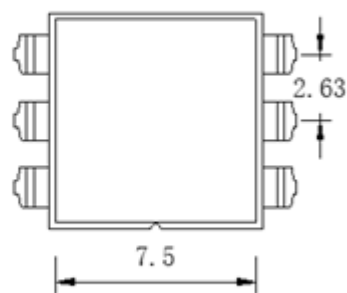
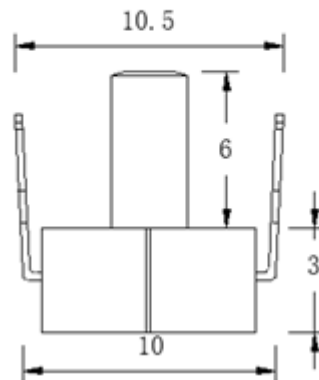
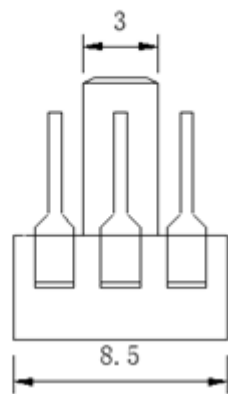
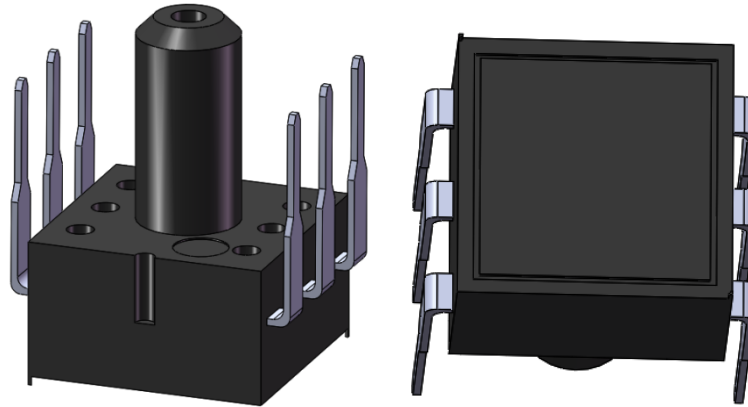

AO100DP DIP6 Bottom Tube TOL: $\pm 0.2\text{mm}$

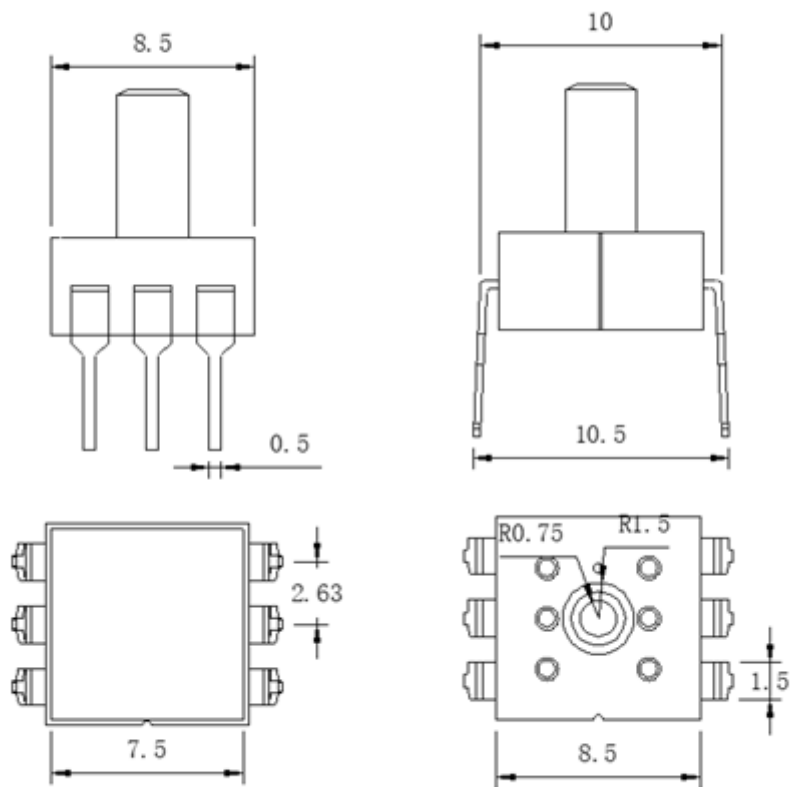
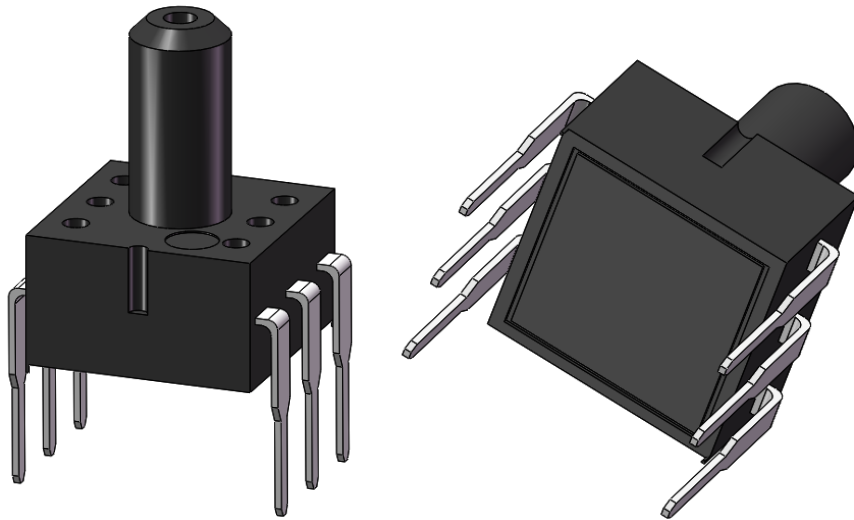

AO100DP DIP6 Top Tube TOL: $\pm 0.2\text{mm}$

9. ORDER INFORMATION

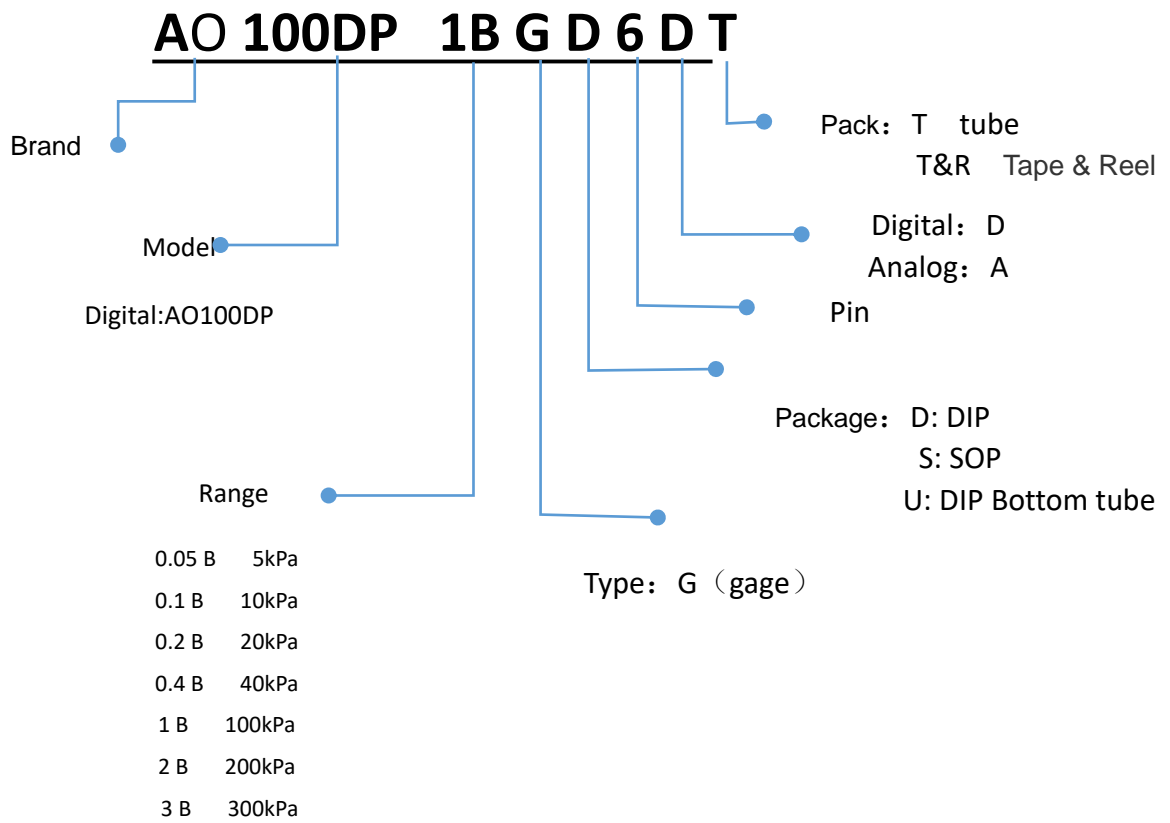

10. SOLDERING RECOMMENDATION

The recommended soldering profile is shown in Figure 1 , followed by a description of the profile features in Table 3 .

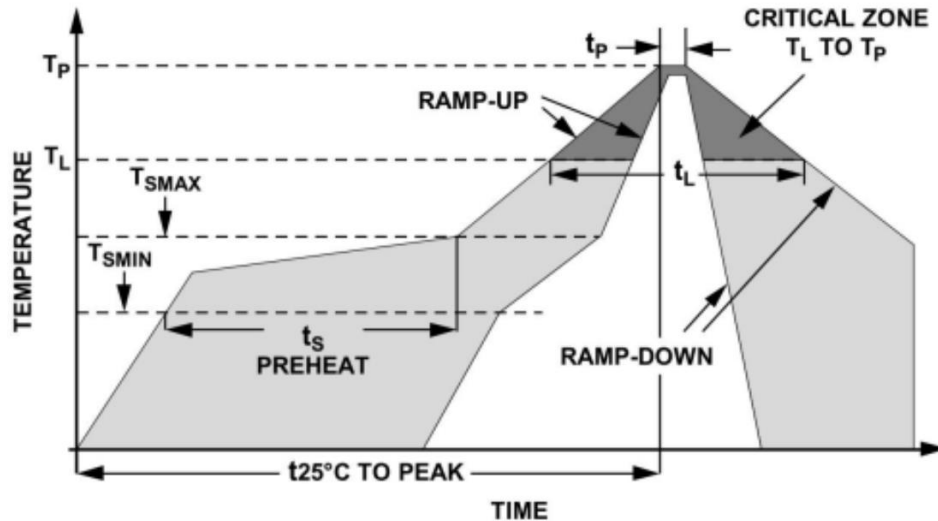

Figure 1 Recommended Soldering Profile

Table 3 Recommended Soldering Profile

Profile Feature	Pb-Free
Average ramp-up rate(T_{sMax} to T_P)	3°C/sec max.
Preheat:	
-Temperature Min.(T_{sMin})	150°C
-Temperature Max.(T_{sMax})	200°C
-Time.(T_{sMin} to T_{sMax})(T_s)	60 sec to 180 sec
Time maintained above:	
-Temperature(T_L)	217°C
-Time(t_L)	60 sec to 150 sec
Peak temperature(T_P)	260°C
Time within 5°C of actual peak temperature(T_P) ²	20 sec to 40 sec
Ramp-down rate	4°C/sec max.
Time 25°C to peak temperature	8 minutes max.