

2 Way Valve with an Actuator

(ATV200-RN)

PRODUCT SPECIFICATION SHEET



FEATURES

- . It's able to separate or assemble an actuator and valve set easily.
- . it's possible to check whether it's close or open.
- . It's possible to control manually when it happens problem.
- . excellent durability

CONTENTS

Features	1
Application	1
Specifications	1~2
Dimensions	2

APPLICATION

This valve is used in the place to improve heat efficiency through control a room temperature properly.
This is opened or closed according to be set temperature.

SPECIFICATION

Medium	Water
Working pressure	0.2 ~ 10kgf/cm ²
Ambient temperature	0 ~ 60℃
Permissible temperature	0 ~ 85℃ (It shall not be frozen)
Electrical rating	220~240 VAC, 3W, 50/60Hz
Permissible differential pressure	2.0kgf/cm ²
Response time	open -> close : 10 ±2sec
	Close -> open : 10 ±2sec
Reverse pressure	1.0 kgf/cm ²
Insulation	More than 100 MΩ (apply 500VDC between electric wire and body)
Withstand voltage	1500VAC/1min (between electric wire and body)

DIMENSIONS

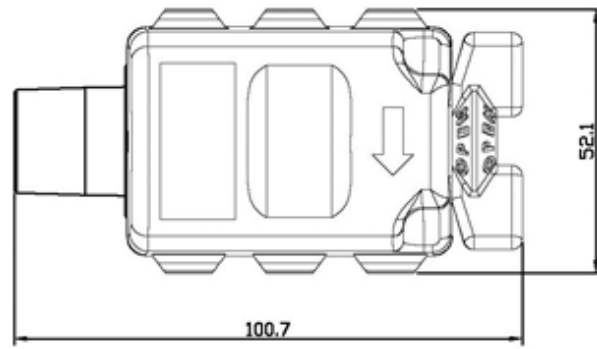

- GREEN (COM)
- BROWN (OPEN)
- BLUE (CLOSE)

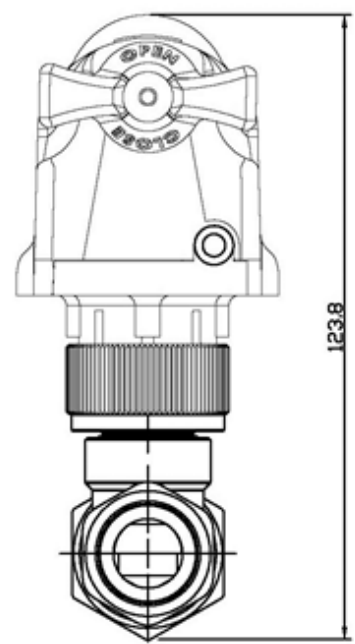
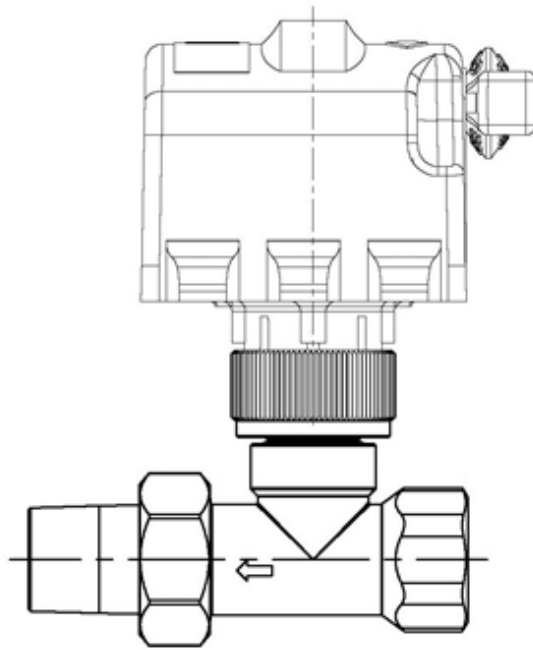
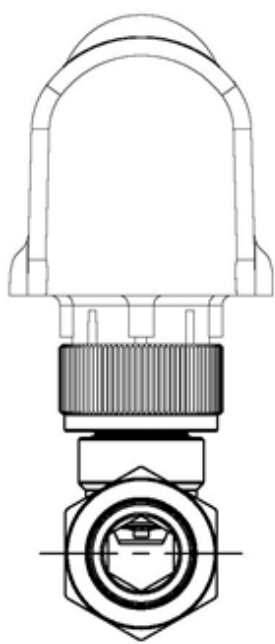

The specifications and dimensions can be changed without warning