

# P-20D

## Compact Pressure Transmitter With I<sup>2</sup>C Digital Output

- Pressure range : 0 to 600mmH<sub>2</sub>O
- Piezo-resistive silicon micro-machined sensor
- Gauge type pressure sensor
- I<sup>2</sup>C interface
- Temperature Compensation : 0 ~ 50°C
- Operating voltage 5.0V
- RoHS compliant and Halogen-free

The P-20D is the pressure sensor which measures gauge pressures. It consists of a silicon micro-machined sensing element chip and a signal conditioning ASIC. The pressure sensor element and the ASIC are mounted inside a system-in-package and wire-bonded to appropriate contacts. The P-20D provides the digital output data with the format of I<sup>2</sup>C interface. It can achieve ESD robustness, fast response time, high accuracy and linearity as well as long-term stability. All measurement data is fully calibrated and temperature compensated. In addition, it allows for easy system integration. Pressure transmitter has a variable semiconductor sensing element with a programmable ASIC and a hybrid circuit for reliable signal conditioning and maximum electronic integration.

□ ASIC Specification [VDD = 5.0V]

Parameter	Test Conditions		MIN	TYP	MAX	UNIT	Symbol
	VDD	Conditions					
Operating Voltage	-	-	4.5	5.0	5.5	V	V <sub>DD</sub>
Operating Current	5.0V	-	-	1.7	2.0	mA	I <sub>DD</sub>
Standby Current	5.0V	System standby	-	0.1	1	μA	I <sub>STB1</sub>
Compensation Temp.	-	-	0	-	+50	°C	T <sub>CMP</sub>
Storage Temp.	-	-	-40	-	+125	°C	T <sub>ST</sub>
Resolution	-	-	-	0.30	-	mmH <sub>2</sub> O	R
Human Body Mode	5.0V	MIL-STD-883E Method 3015.7	-	2	-	kV	ESD
Pressure Accuracy (Temp error)	5.0V	T : 0°C ~ 50°C P : 0 ~ 600mmH <sub>2</sub> O	-5.0	-	+5.0	mmH <sub>2</sub> O	P <sub>ACC</sub>
Load Resistance	-	T <sub>A</sub> = 25°C	9	-	10	kΩ	R <sub>L</sub>
Humidity	-	T <sub>A</sub> = 25°C	-	-	95	%RH	R <sub>H</sub>
Over pressure	-	T <sub>A</sub> = 25°C, Both Ports	1,300	-	1,800	mmH <sub>2</sub> O	P <sub>O</sub>
Burst pressure	-	T <sub>A</sub> = 25°C, Port 1	2,000	-	3,000	mmH <sub>2</sub> O	P <sub>B</sub>
Solder Temp.	-	T <sub>A</sub> = 250°C	3	-	5	Sec.	T <sub>S</sub>

□ Operating Conditions

Operating Conditions						
Parameter	MIN	TYP	MAX	UNIT	Symbol	
Positive Supply Voltage for IC Operation	4.5	-	5.5	V	V <sub>DD</sub>	
Bridge Resistance (ideal)	2.7	3.3	3.9	KΩ	R <sub>BRG</sub>	
Ambient Temperature Range, Operating Range	-30	-	85	°C	T <sub>amb</sub>	
External Capacitance between VDD and Ground (VSS)	0.47	10	20	μF	C <sub>VDD</sub>	
Pull-Up Resistance on SDA	1.0	10	-	KΩ	R <sub>PU</sub>	



### TYPICAL APPLICATIONS

- ✓ Transmissions
- ✓ Compressors & Pumps
- ✓ Water Management
- ✓ Environment control systems

## □ Main ASIC Part Diagram

Diagram

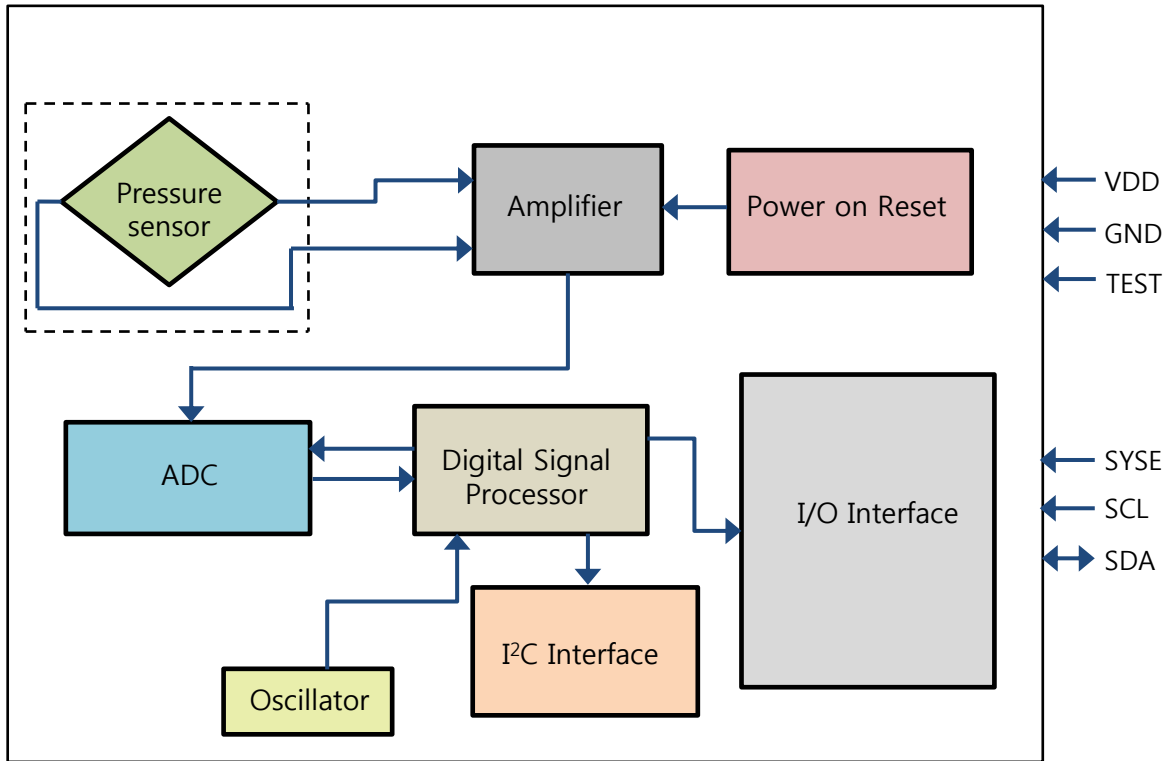

## Pin Configuration

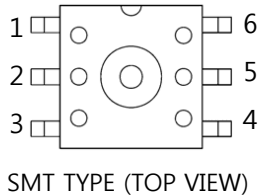

## Pin Description

Pin No.	Pin Name	I/O	Function description
1	SCL	I	Serial Data Input (Open Drain Output)
2	SDA	I/O	Serial Data Input / Output (Open Drain Output)
3	VSS	-	Connected to GND
4	TEST	-	Connected to VDD
5	VDD	-	Connected to VDD
6	SYSE	I	System Enable / Disable

## System Reading Timing

chart

Note :  $T_D$  is required for sensor to get thermo stabilized after being activated.  
Data retrieved within  $T_D$  period might be incorrect.

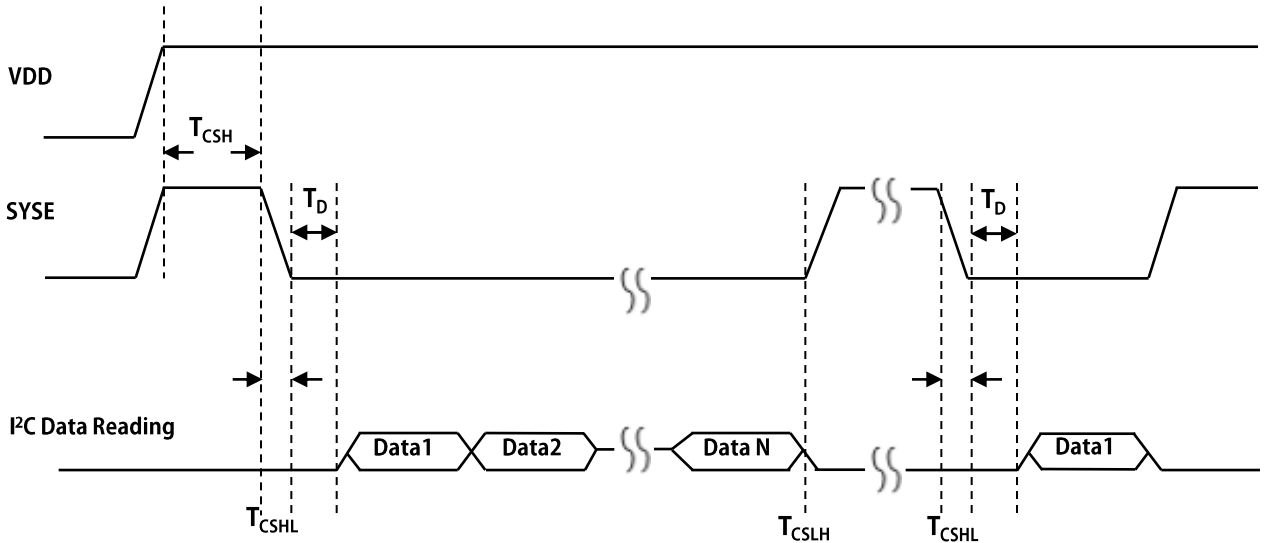

## Data Update Timing

chart

Note :  $T_D$  is required for sensor to get thermo stabilized after being activated.  
Data retrieved within  $T_D$  period might be incorrect.

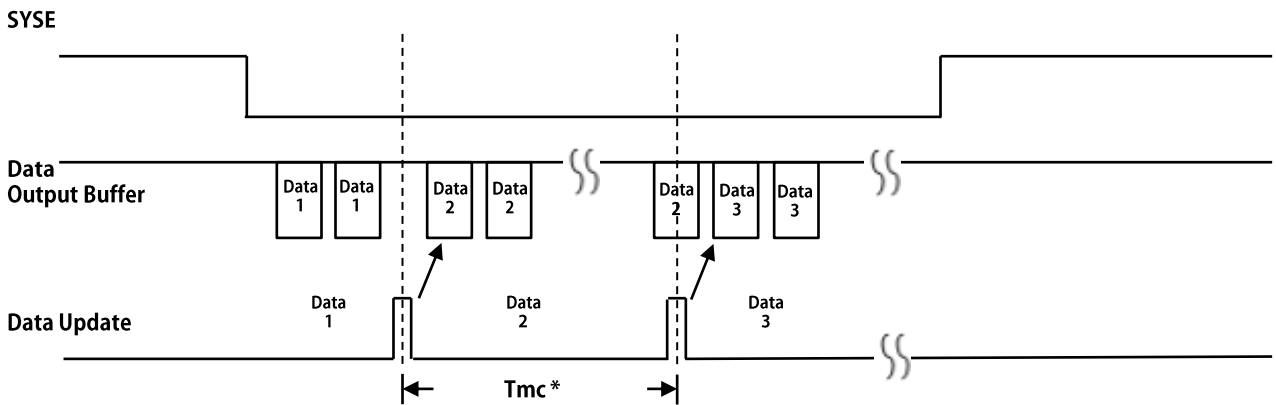

Symbol	Parameter	Min.	Typ.	Max.	Unit
$T_{CSH}$	CS High Hold Time	100	-	-	$\mu$ S
$T_{CSHL}$	CS High To Low Time	-	-	1	mS
$T_{CSLH}$	CS Low To High Time	-	-	1	mS
$T_D$	Chip Enable Delay Time	400	-	-	mS
$T_{mc}^*$	Data Update Time	20	-	40	mS

## ADC Buffer and I<sup>2</sup>C Buffer Data Transfer Logic and sequence illustration

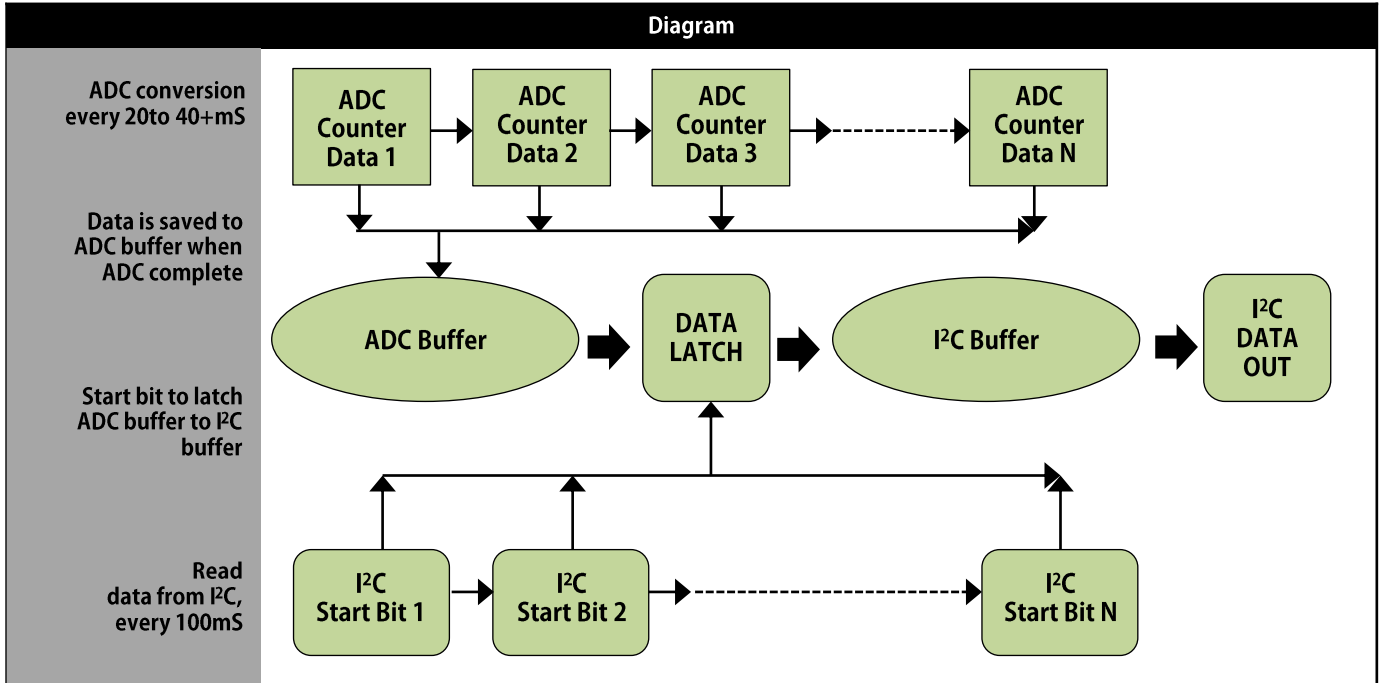

## The data load Timing of Pressure ASIC

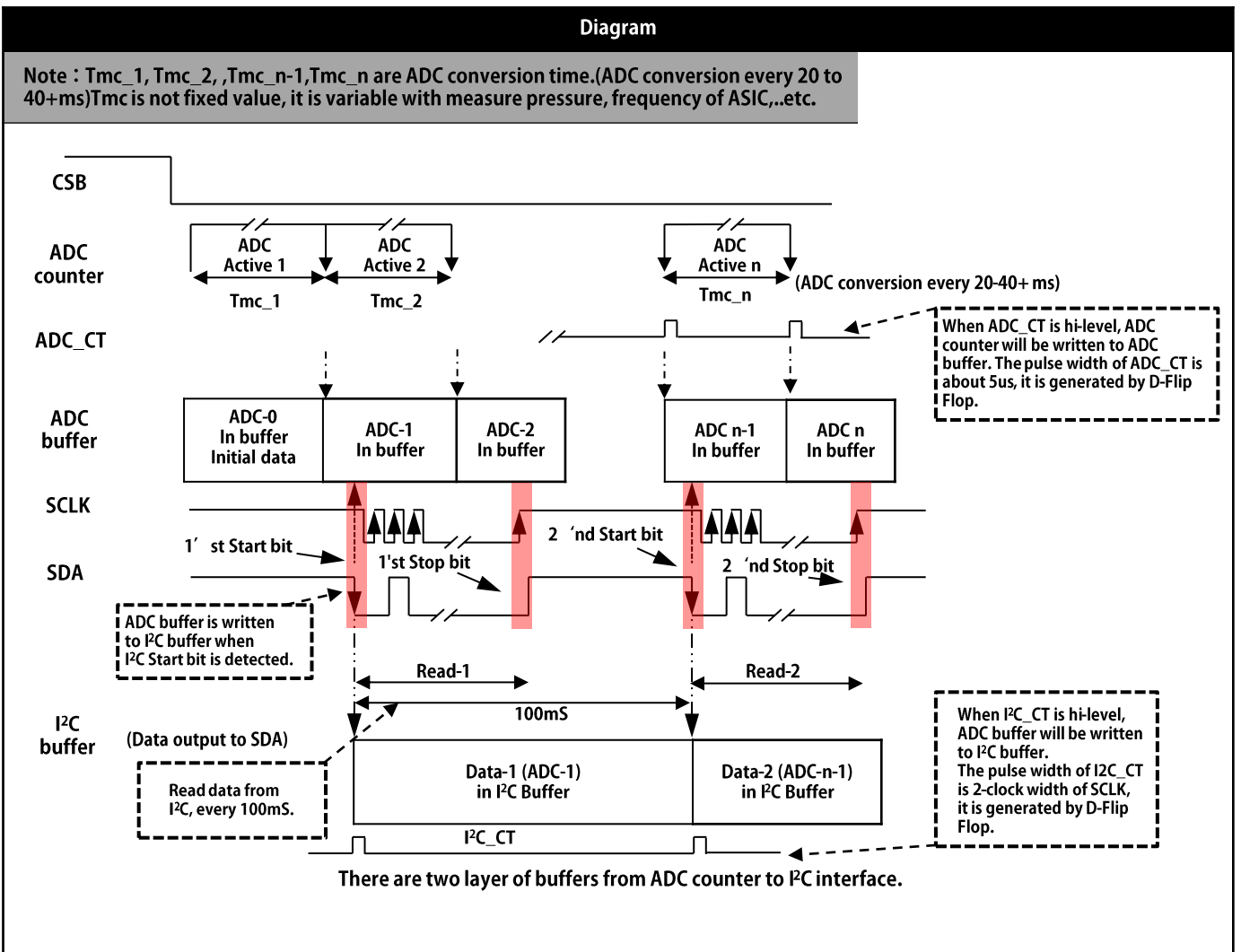

## □ ASIC I<sup>2</sup>C Interface

### Chart

The data transfer format of I2C (ADC with 12 bits resolution) Master read (Master—Receiver; Slave—Transmitter)

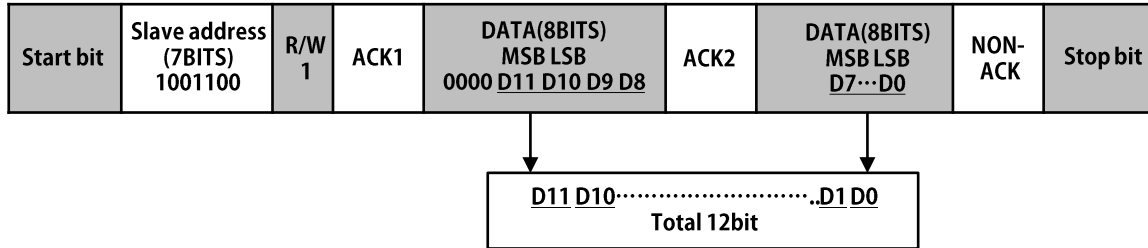

Each sensor is referenced on the bus by a 7 bit slave address. The slave address is 1001100. The eighth bit of control address is read or written which assigned by processor.

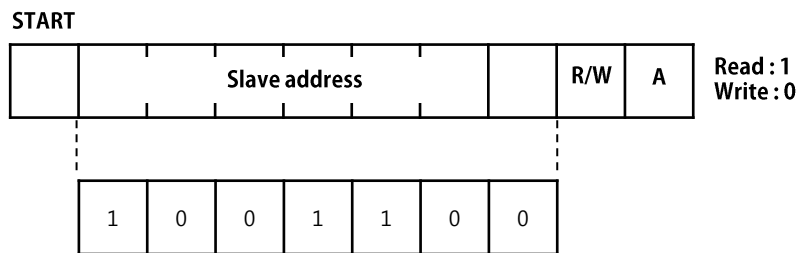

Figure 1. Control address byte

## □ I<sup>2</sup>C Pressure Measurement Packets

### Chart

- ❖ ACK1 : That should respond a ACK1 (Low) signal to the microcontroller.
- ❖ ACK2 : The microcontroller should respond a ACK2 (Low) signal to the sensor.
- ❖ NON ACK : The microcontroller should respond a NON-ACK (High) signal the sensor.
- ❖ I<sup>2</sup>C Reading Code Example : If needed, you can refer to example in this document.

#### Two Byte Data read out

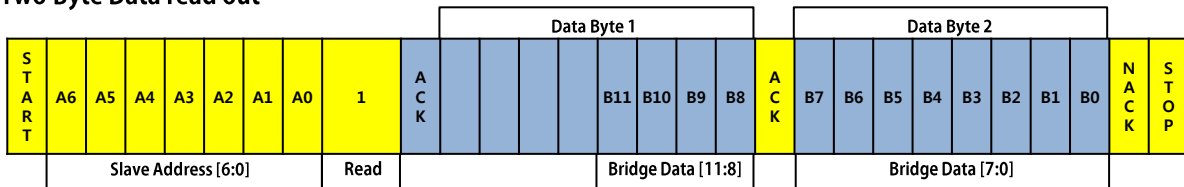

#### Two Byte Data Write

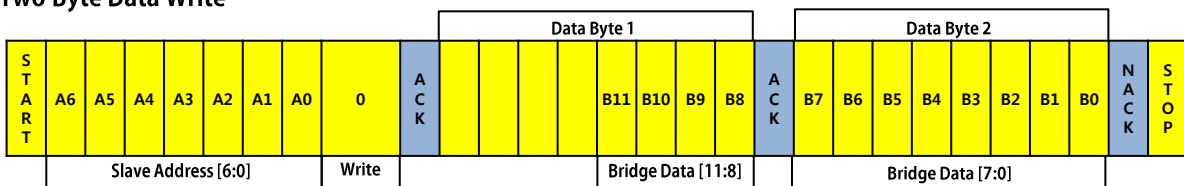

From master to slave (Yellow box)      From slave to master (Blue box)

**□ Bus protocol**

chart

- ❖ Data transfer may be initiated only when the bus is not busy.
- ❖ During data transfer, the data line must keep stable whenever the clock is HIGH level. Changes in the data line while the clock line is HIGH will be interpreted as a start or stop condition.
- ❖ Following bus conditions has been defined as Figure 2.

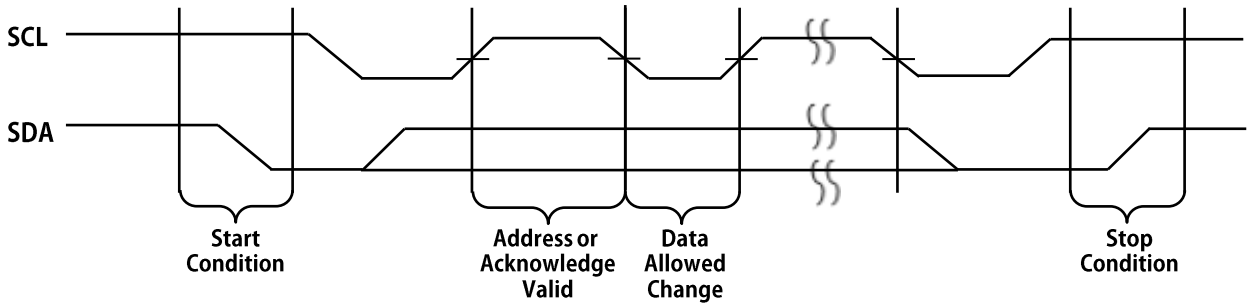
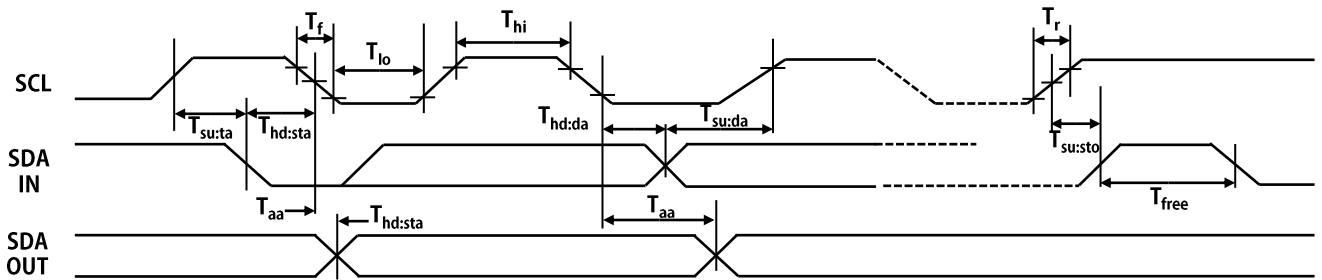

Figure 2. Data transfer sequence on serial bus

**□ The data bus timing**

chart



When the bus is free, both lines are pulled up to +ADD. Data on the I<sup>2</sup>C-bus can be transferred at a rate up to 100 kbit/s in the standard-mode, or up to 400 kbit/s in the fast-mode.

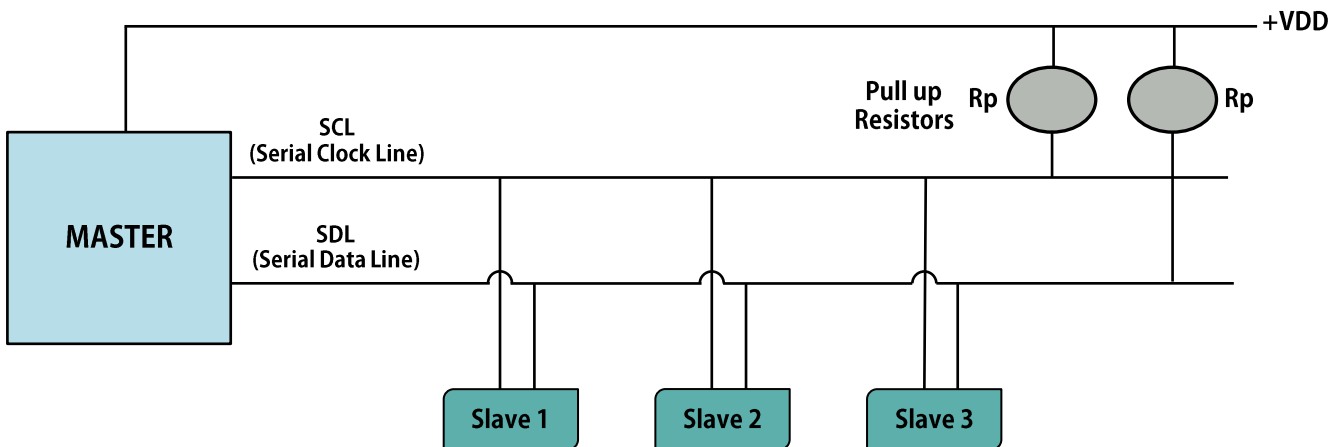

Figure 3. I<sup>2</sup>C Bus Configuration

## A.C. Characteristic

Symbol	Parameter	Standard mode		Fast mode			Unit
		MIN	MAX	MIN	Typical	MAX	
$F_{scl}$	Clock frequency	-	100k	-	400k	2M	Hz
$T_{hi}$	Clock high time	4,000	-	600	-	-	nS
$T_{lo}$	Clock low time	4,700	-	1,300	-	-	nS
$T_r$	SCL and SDA rise time	-	1,000	-	300	-	nS
$T_f$	SCL and SDA fall time	-	300	-	300	-	nS
$T_{hd:sta}$	START condition hold time	4,000	-	600	-	-	nS
$T_{su:sta}$	START condition setup time	4,700	-	600	-	-	nS
$T_{hd:da}$	DATA input hold time	0	-	-	0	-	nS
$T_{su:da}$	DATA input setup time	250	-	100	-	-	nS
$T_{su:sto}$	STOP condition setup time	4,000	-	600	-	-	nS
$T_{aa}$	Output valid from clock	-	3,500	-	900	-	nS
$T_{free}$	Bus free time	4,700	-	1,300	-	-	nS

## Pressure versus Digital output value (Typical)

chart

The relationship between digital output value and pressure is given as show below

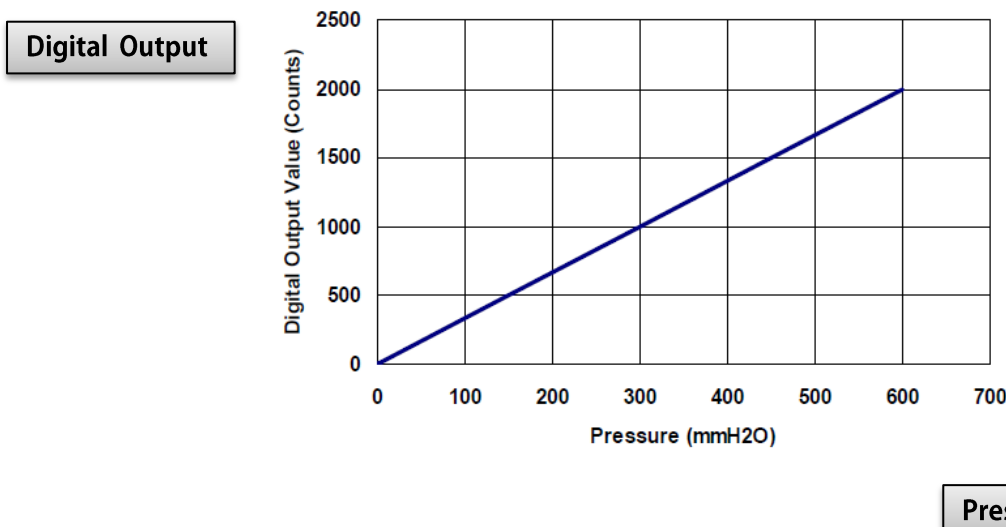

$$\text{Pressure (mmH}_2\text{O)} = \text{Output Value} \times 0.3$$

□ Reading Flow (I<sup>2</sup>C Interface)

Chart

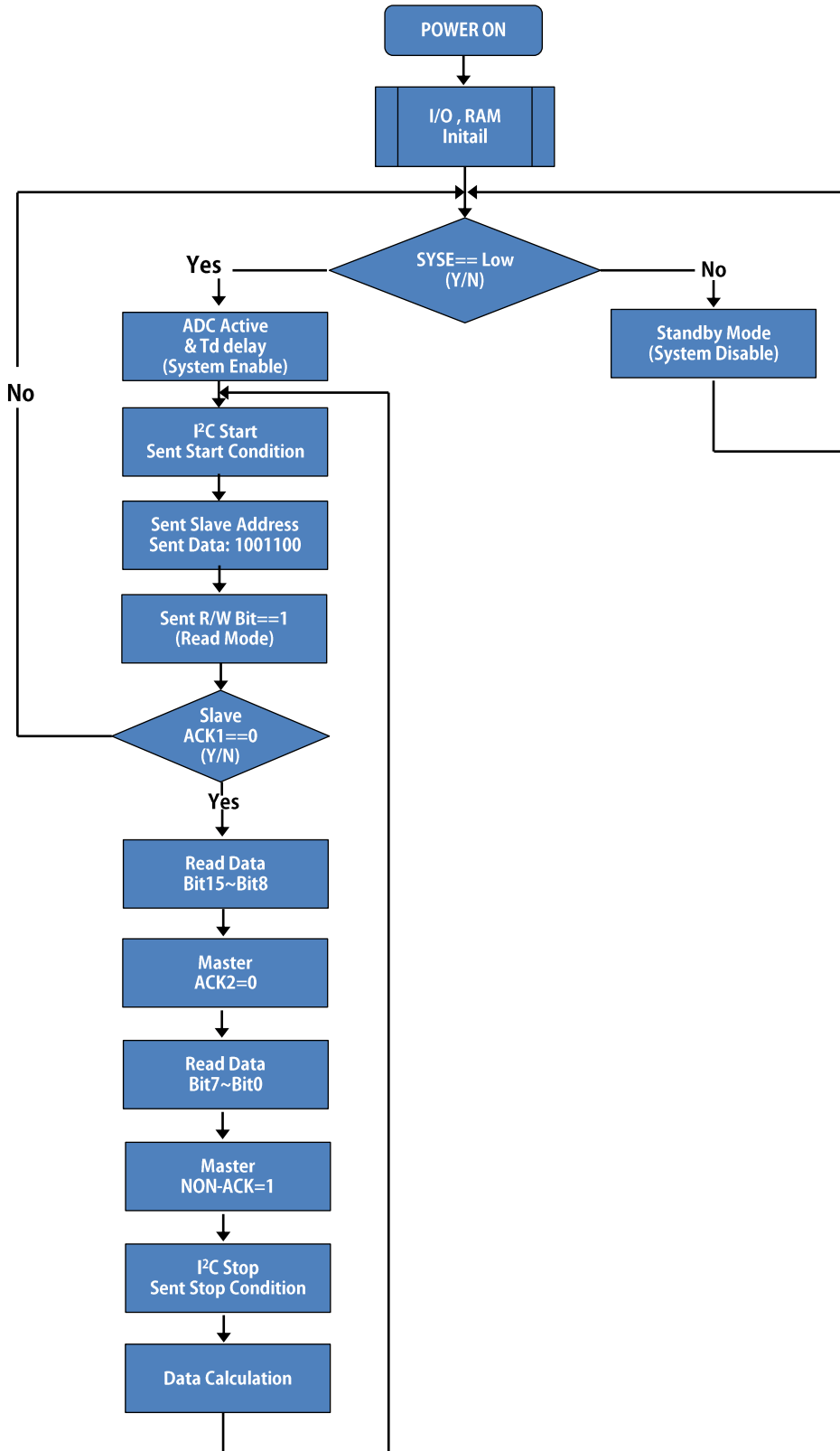

Bit No.	Description	Note
Bit 15	ADC Data Bit	Normal = 0
Bit 14	ADC Data Bit	Normal = 0
Bit 13	ADC Data Bit	Normal = 0
Bit 12	ADC Data Bit	Normal = 0
Bit 11	ADC Data Bit	
Bit 10	ADC Data Bit	
Bit 9	ADC Data Bit	
Bit 8	ADC Data Bit	
Bit 7	ADC Data Bit	
Bit 6	ADC Data Bit	
Bit 5	ADC Data Bit	
Bit 4	ADC Data Bit	
Bit 3	ADC Data Bit	
Bit 2	ADC Data Bit	
Bit 1	ADC Data Bit	
Bit 0	ADC Data Bit	

Notice:

- ❖ ACK1: Should respond a ACK1 (Low) signal to the microcontroller.
- ❖ ACK2: The microcontroller should respond a ACK2 (Low) signal to the sensor.
- ❖ NON ACK: The microcontroller should respond a NON-ACK (High) signal to the sensor.



## Application Circuit

### Circuit

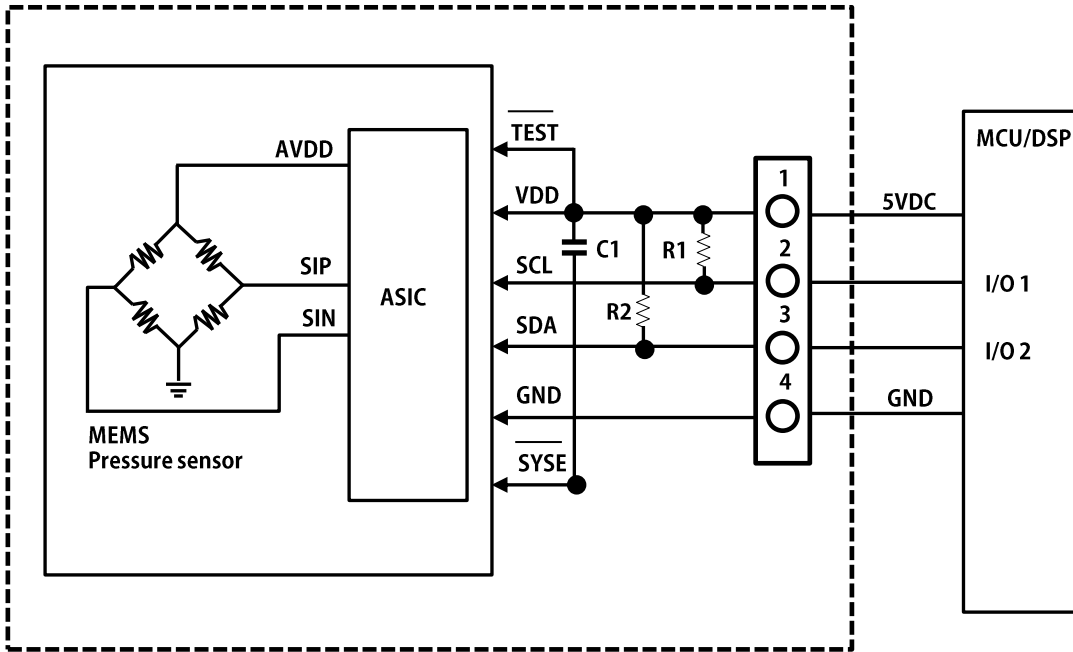

#### Notice:

- ❖ R1, R2 : Pull-up Resistor (1K $\Omega$ ~10K $\Omega$ )
- ❖ C1, C2 : 4.  $\mu$ F

## SENSOR Dimensions(mm)

### Dimensions(mm)

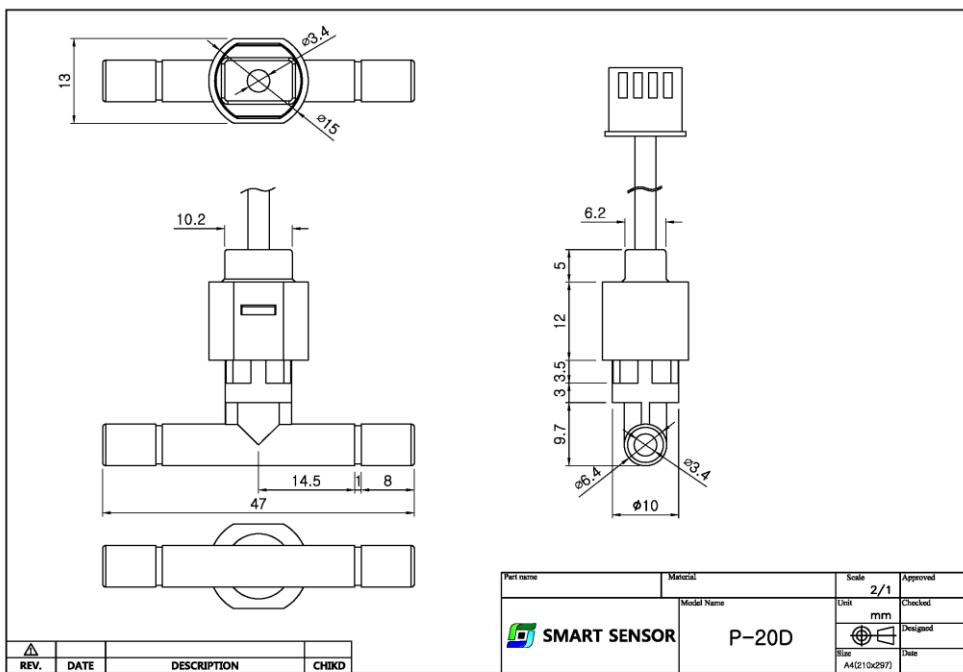

## How to order

	P - 20	D	<input type="checkbox"/>	<input type="checkbox"/>	<input type="checkbox"/>	<input type="checkbox"/>	<input type="checkbox"/>
<b>1) Output signal</b>							
I <sup>2</sup> C	D						
<b>2) Kind of pressure</b>							
Absolute pressure	-----	A					
Gauge pressure	-----	G					
<b>3) Pressure range</b>							
0 to 600 mmH <sub>2</sub> O	-----	-----	600				
Other on request	-----	-----	Z				
<b>4) Supply Voltage</b>							
5.0 VDC	-----	-----	-----	5			
<b>5) Process connection</b>							
UNF1/4"	-----	-----	-----	-----	U14		
Other on request	-----	-----	-----	-----	Z		
<b>6) Seal material</b>							
Silicone	-----	-----	-----	-----	S		
NBR	-----	-----	-----	-----	N		
Viton	-----	-----	-----	-----	V		
Ethylene	-----	-----	-----	-----	E		
Neoprene	-----	-----	-----	-----	P		
Other on request	-----	-----	-----	-----	Z		
<b>7) Cable Length</b>							
1,000mm	-----	-----	-----	-----	-----	1000	
Other on request	-----	-----	-----	-----	-----	Z	